

SMARTux
HS-630i

**ULTRA *HIGH-SPEED* PRECISION
HORIZONTAL MACHINING CENTER**



**CINCINNATI
MACHINES**

HS-630i

SMARTUX HS-630i is the ultimate high speed, high precision, heavy-duty state-of-the-art horizontal machining center. It comes packed with highly advanced technological features that will insure high production rates. SMARTux horizontal machining centers are designed and manufactured from the ground up to insure superior quality throughout. In other words, do it smart and don't make it so complicated. If you can accomplish something smart with less parts, then it will cost less and the unnecessary parts can't break down.



Main Features



Rigid Structure

The dual-wall machine column is a symmetrical casting design for thermal stability. The machine base is made of a heavily ribbed, one-piece cast iron to ensure the superb rigidity for cutting exotic materials.

- One-piece machine base casting for long term cutting rigidity and precision.

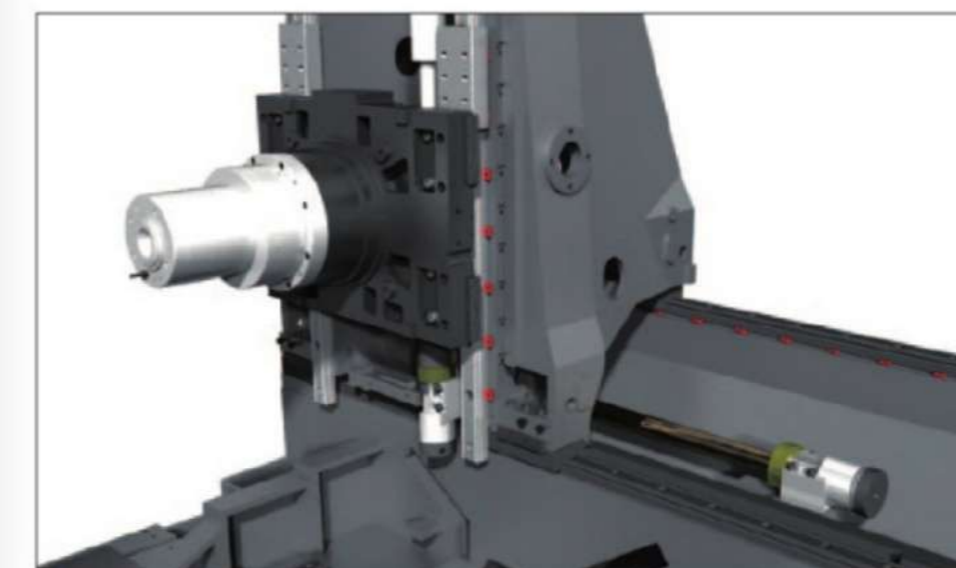

- Stepped castings design on machine base to increase the cutting rigidity.

- 100% Hand-scraping



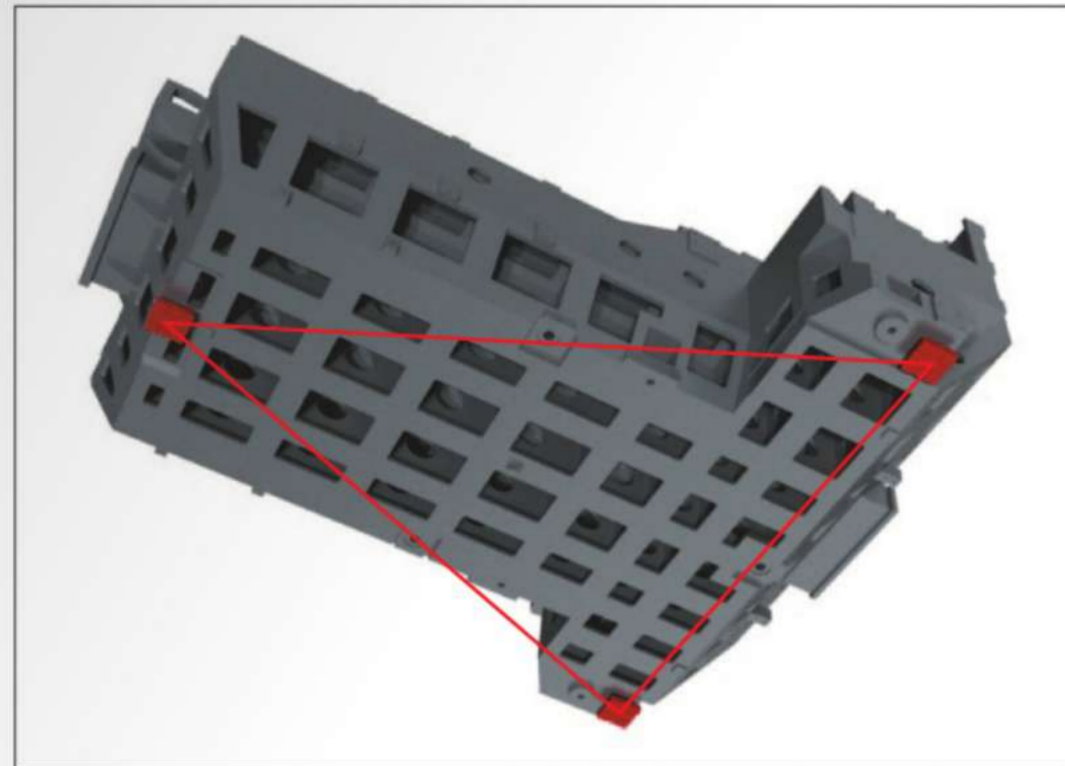

■ 3 Points Leveling

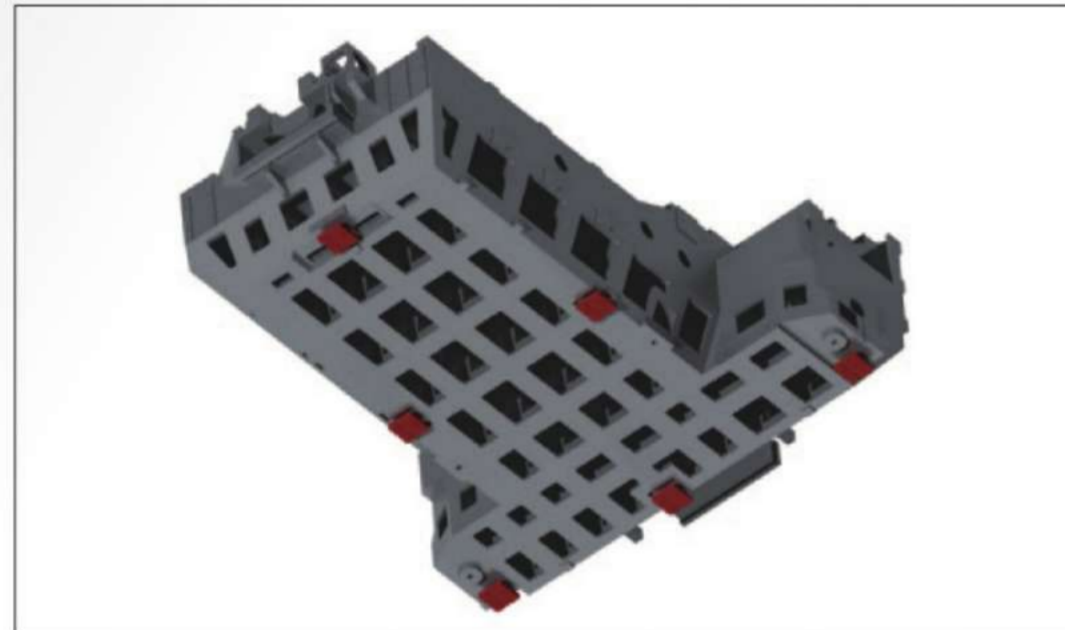

■ 6 Points Foundation Supports

■ Roller Guides by **THK**[®] Japan

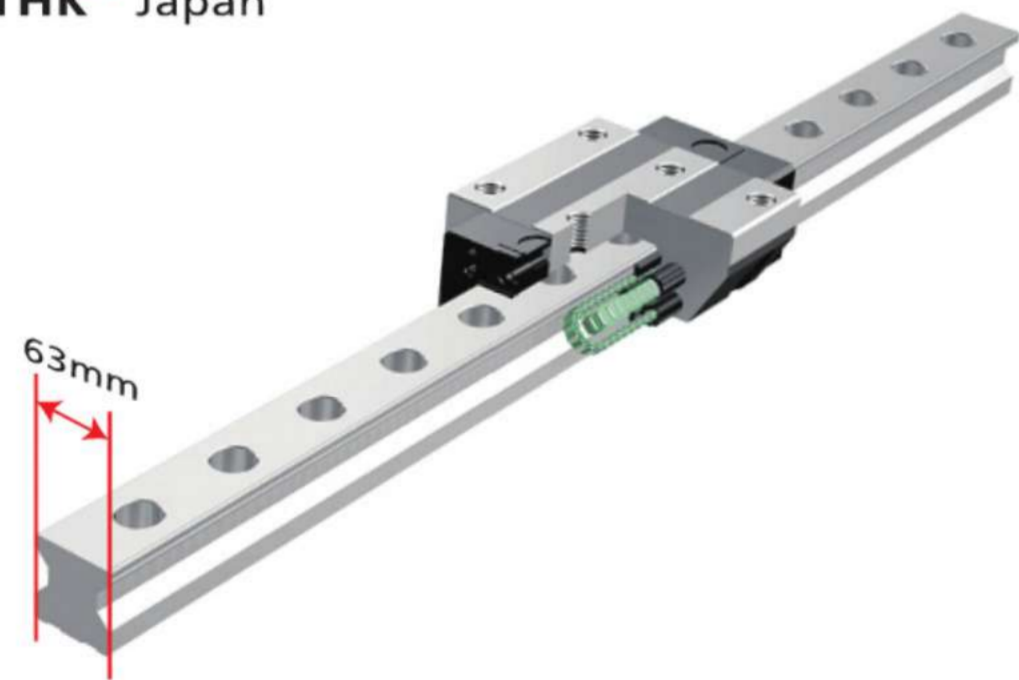

■ Precision Ball Screws by **TSUBAKI**[®] Japan



Main Features

High Speed

Specs	630i	X Y Z
Rapid		50 m/min
Cutting		20 m/min
Acceleration		0.7 G/1 G/0.9 G

High Precision

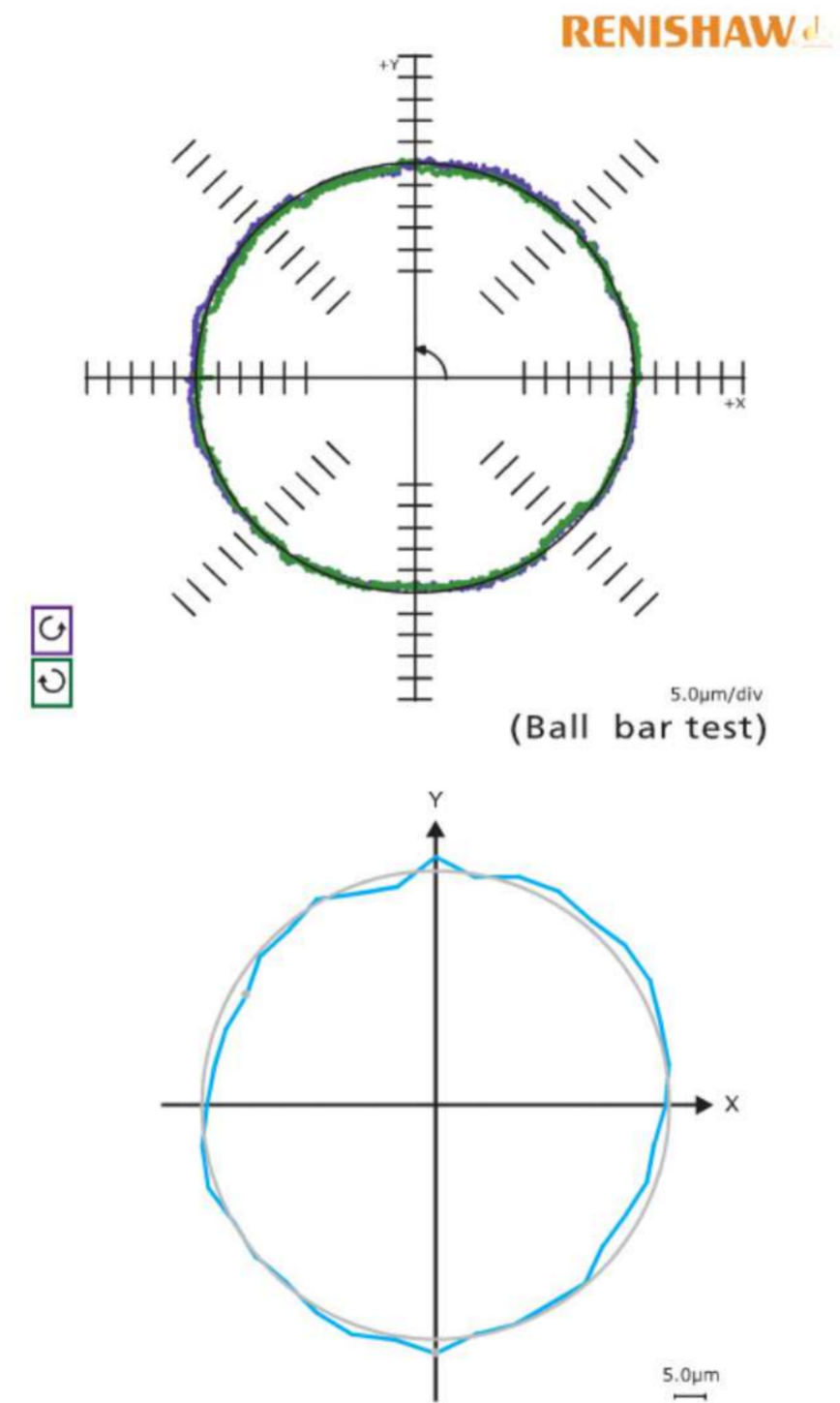

Circularity: **5.9*** µm

Feed Rate	1,000 mm/min
Radius	150 mm

Roundness: **4.8*** µm

Material	AL6610 (Φ 200 mm)
Tool	Φ20 mm (3T)
Spindle Speed	4,777 rpm
Feed Rate	1,453 mm/min

* Data obtained from a machine with a solid foundation in a temperature control environment.

Positioning & Repeatability (ISO 10791-4)

Standard Code	ISO 10791-4	HS-630i
Travel	Full Stroke	Full Stroke
Positioning A	0.025 mm (0.00098")	0.0029 mm (0.00011")
Repeatability R	0.015 mm (0.00059")	0.0021 mm (0.00008")

Main Features

Thermal Stability

All ballscrews are core-cooled.

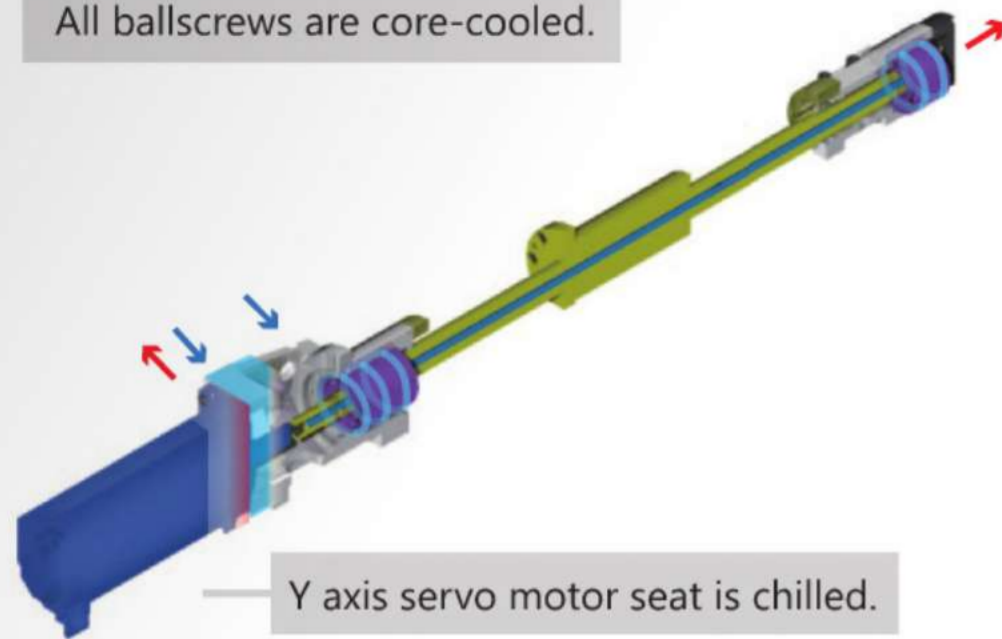

Y axis servo motor seat is chilled.

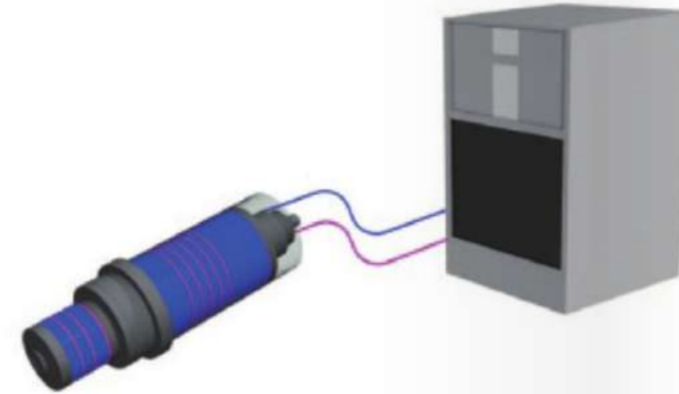

Spindle temperature is constantly controlled by oil chiller.

Superior Cutting Performance

(10,000 rpm standard spindle)

Maximum Chip Removal

Face Milling Chip Removal Rate: **4800** cc/min Material: Al (6061)

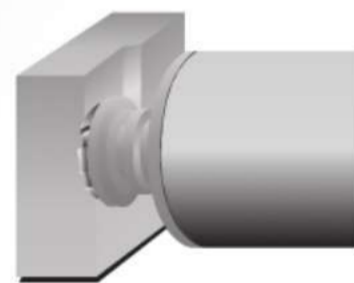

Tool	Ø100mm x 7T
Spindle Speed	10,000 rpm
Feed Rate	12,000 mm/min
Width of Cut	80 mm
Depth of Cut	5.0 mm
Spindle Load	214 %

Face Milling Chip Removal Rate: **810** cc/min Material: Steel (S45C)

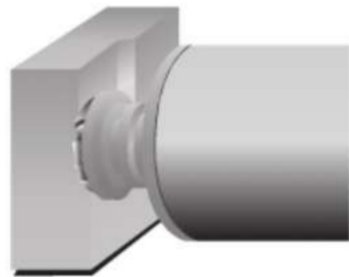

Tool	Ø125mm x 8T
Spindle Speed	675 rpm
Feed Rate	3,240 mm/min
Width of Cut	100 mm
Depth of Cut	2.5 mm
Spindle Load	120 %

Face Milling Chip Removal Rate: **272** cc/min Material: Steel (S45C)

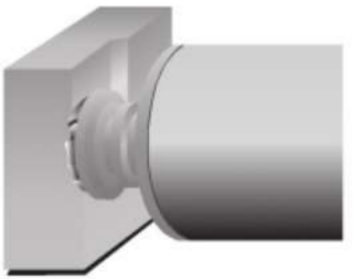

Tool	Ø160mm x 8T
Spindle Speed	320 rpm
Feed Rate	256 mm/min
Width of Cut	125 mm
Depth of Cut	8.5 mm
Spindle Load	90 %

Drilling Chip Removal Rate: **512.4** cc/min Material: Steel (S45C)

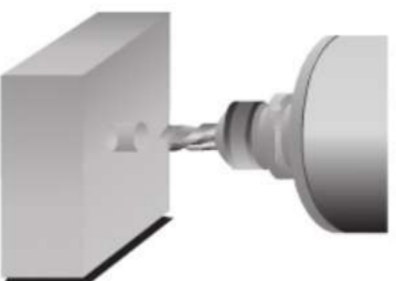

Tool	Ø80mm x 2T
Spindle Speed	750 rpm
Feed Rate	188.4 mm/min
Spindle Load	94 %

Rigid Tapping Material: Steel (S45C)

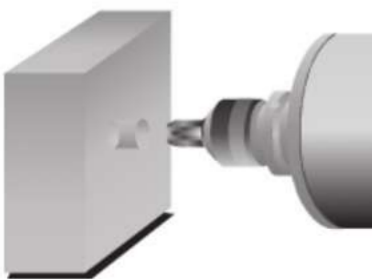

Tool	M56X5.5P
Spindle Speed	58 rpm
Feed Rate	319 mm/min
Spindle Load	145 %

Main Features

Spindle

Spindle	Standard	High Torque OP
Max. Spindle Speed	10,000 rpm	8,000 rpm
Spindle Motor Power	45 kW	55 kW
Spindle Rated Torque	600 Nm	1,200 Nm

Oversized ceramic spindle bearings are utilized for superior cutting performance and constant precision.



10,000 rpm **ST**



8,000 rpm **OP**

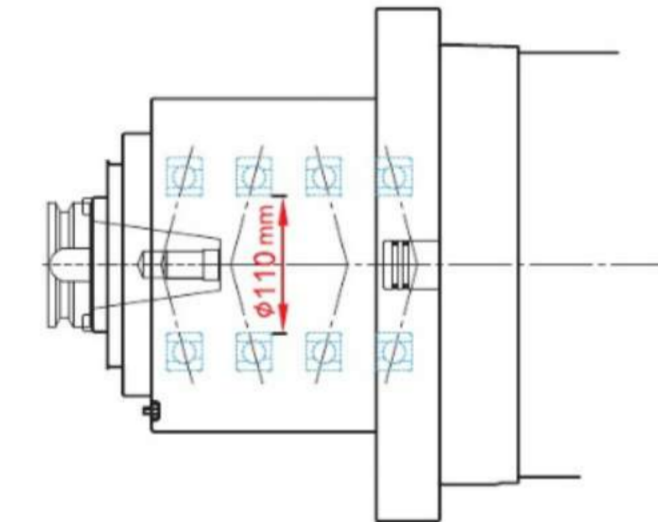
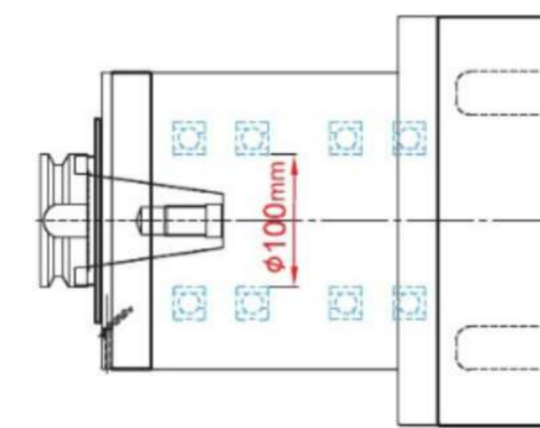

30 Bar Coolant Thru Spindle **ST**

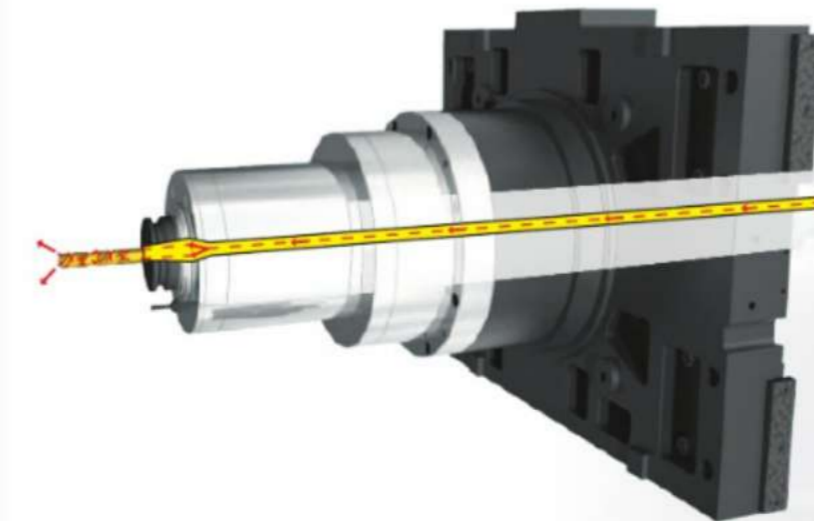

BBT Dual Surface Contact Spindle Design **ST**

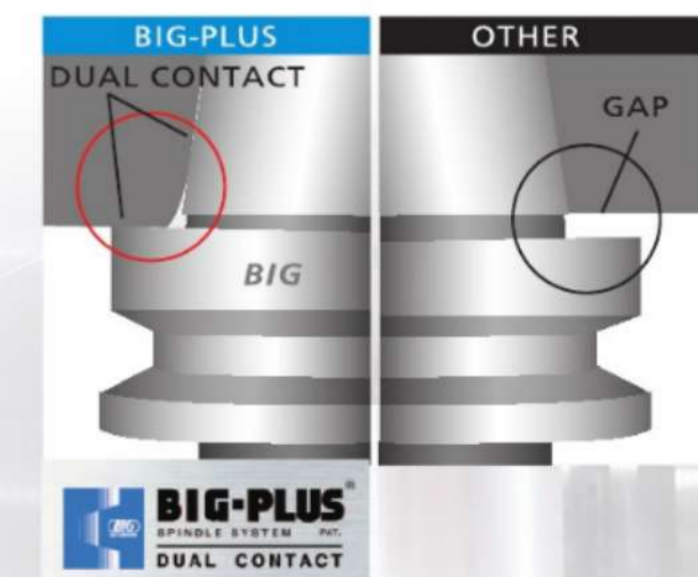

- 6 Spindle Coolant Nozzles
- Cutting Air Thru Spindle
- Spindle Air Blast (tool changing)



Spindle Output Diagrams

Standard

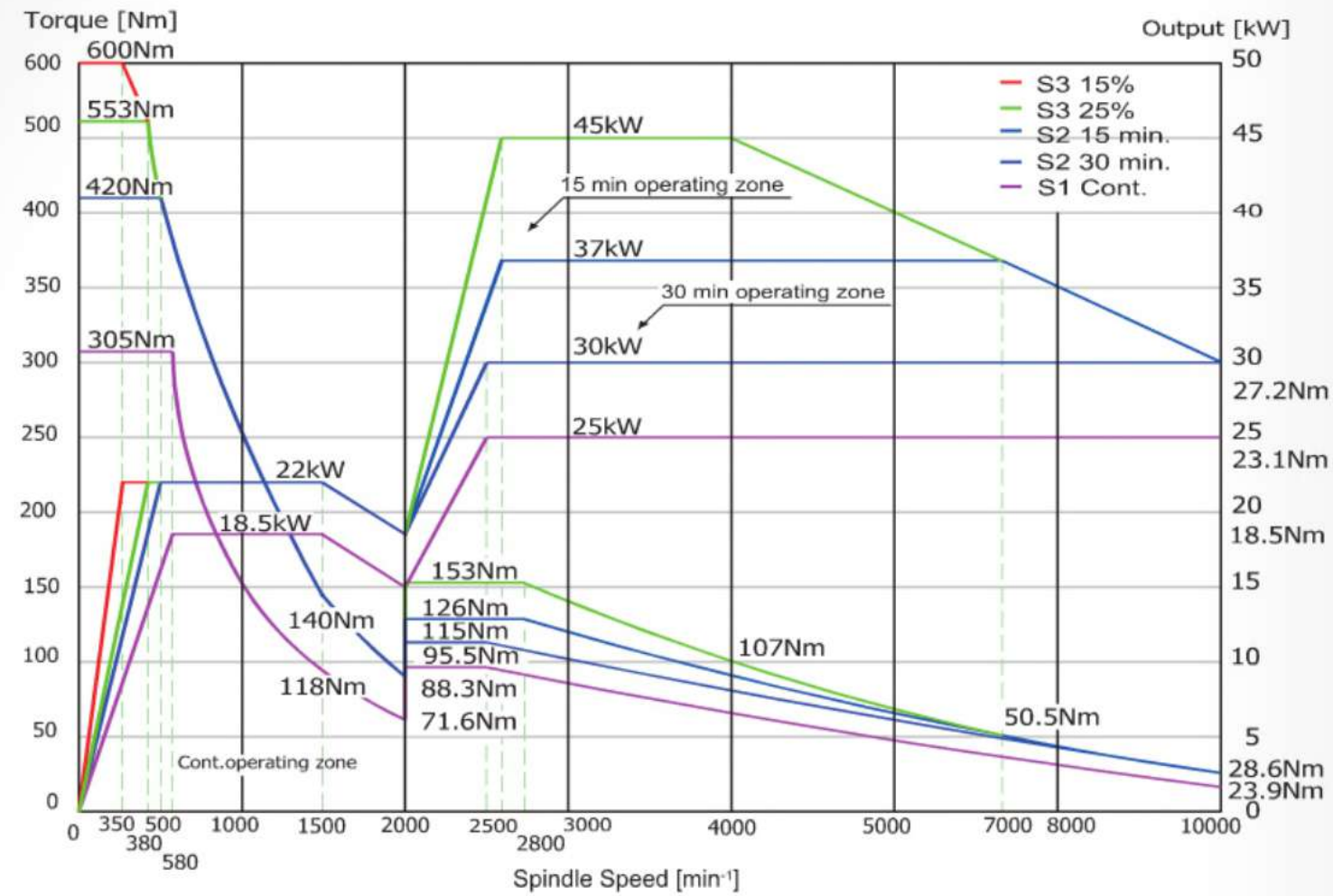

High Torque OP

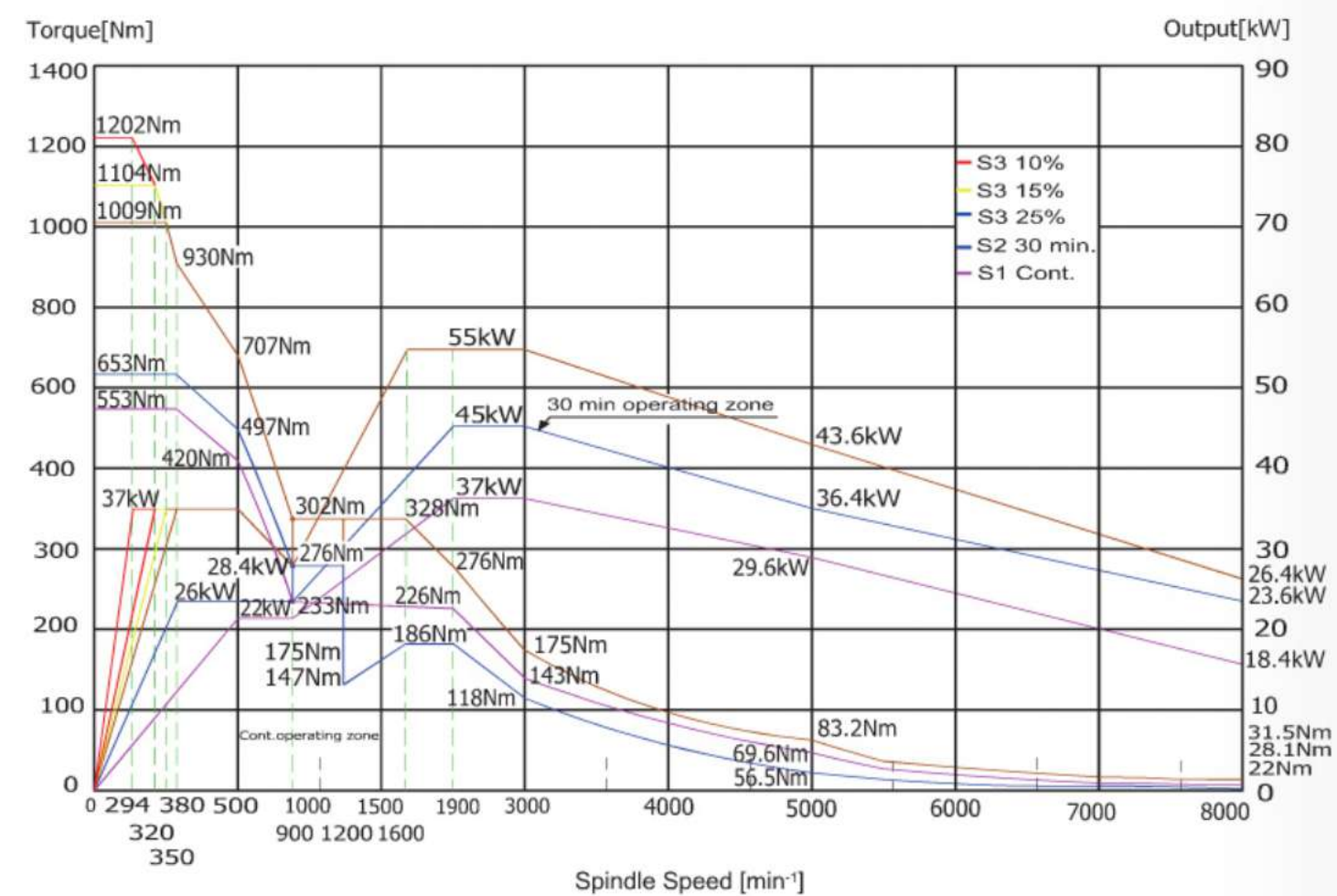

Automatic Tool Changer (ATC)

- 60 tools capacity tool magazine.
- Tool magazine is servo motor driven.
- Tool searching is fully programmable (stop/go,slow/fast).



Ring Type 60 Tools ST



Chain Type 120 Tools OP

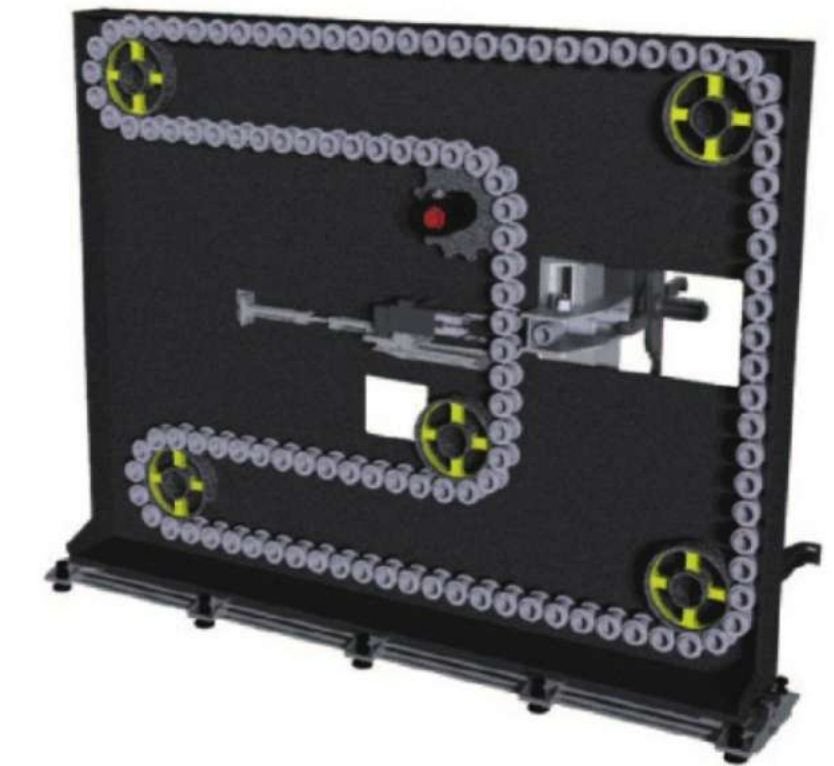

Tool Specifications

With adjacent tool(s)



Without adjacent tool(s)



Automatic Pallet Changer (APC)

Rotary Table

- Standard: PARKSON® 1° indexing Table.
- Optional:
 - PARKSON® 0.001° full 4th axis Rotary Table.
 - TSUDAKOMA® 0.001° full 4th axis Rotary Table.

Pallet Clamping System

- 4 tapered cones equipped with air sensors to confirm the pallets are accurately positioned and seated.
- Pallets are mechanically clamped by a ball locking system which generates a powerful 6,400 kgf clamping force.
- High pressure air cleans the pallet during changing cycles.

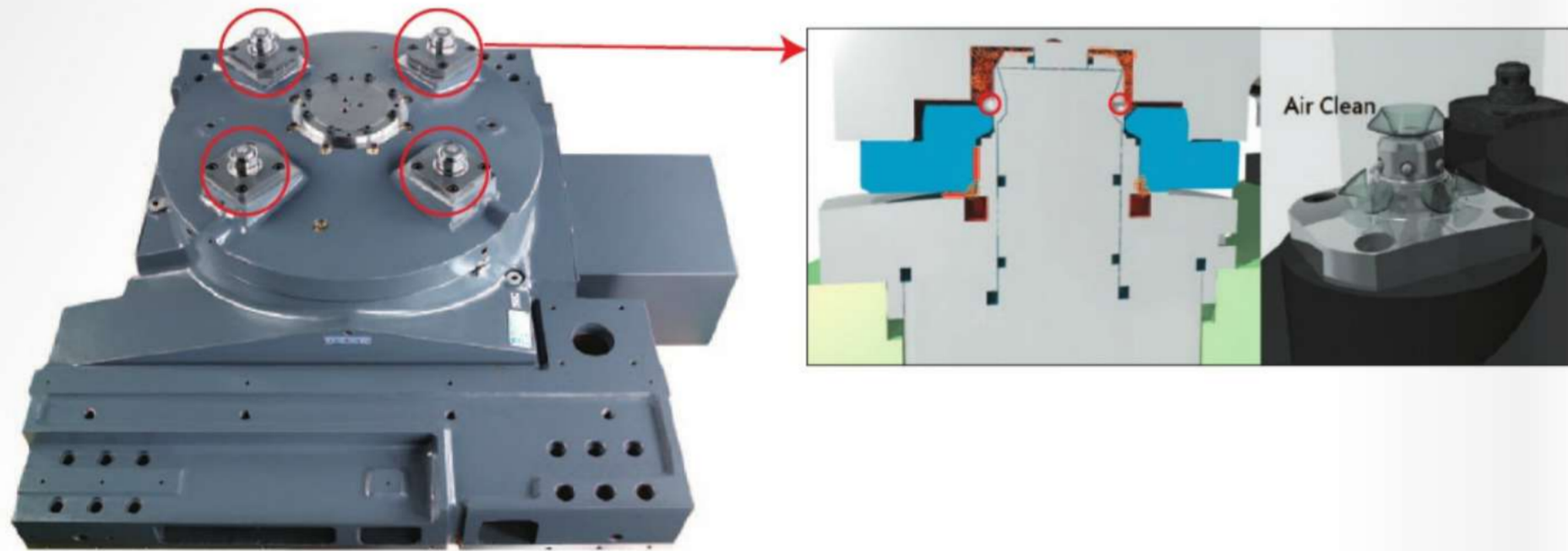

Machining Envelope

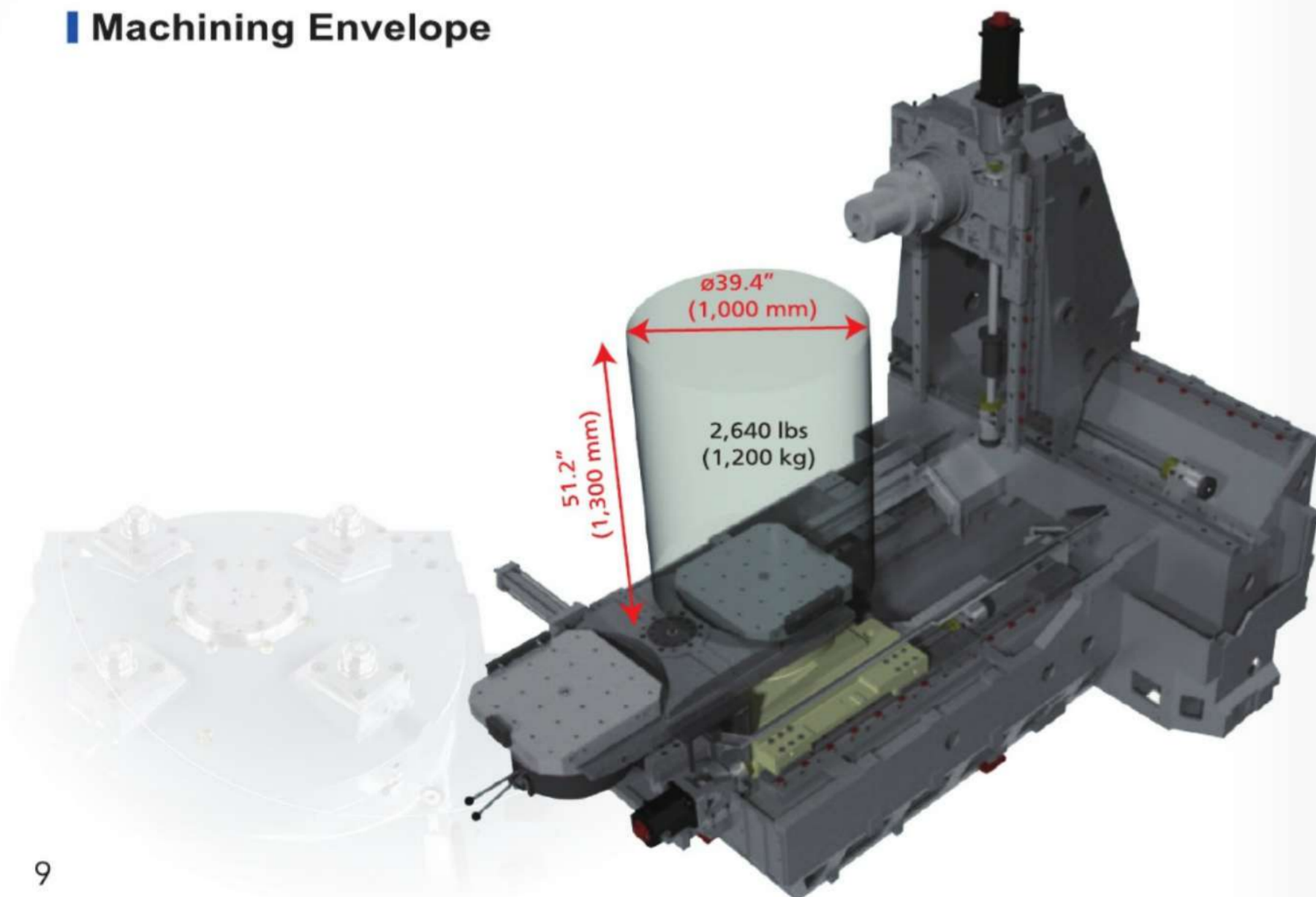

6 Pallet Pool Expansion Unit

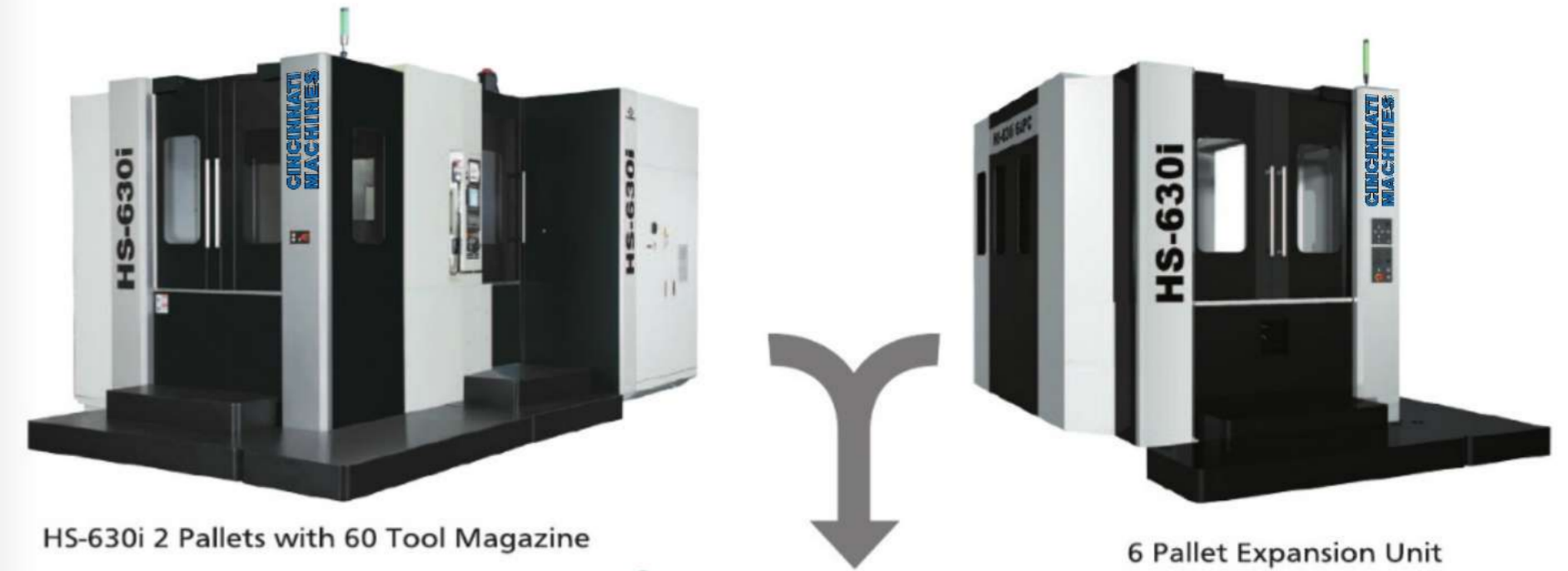

HS-630i with 6 Pallets and your choice of tool magazine

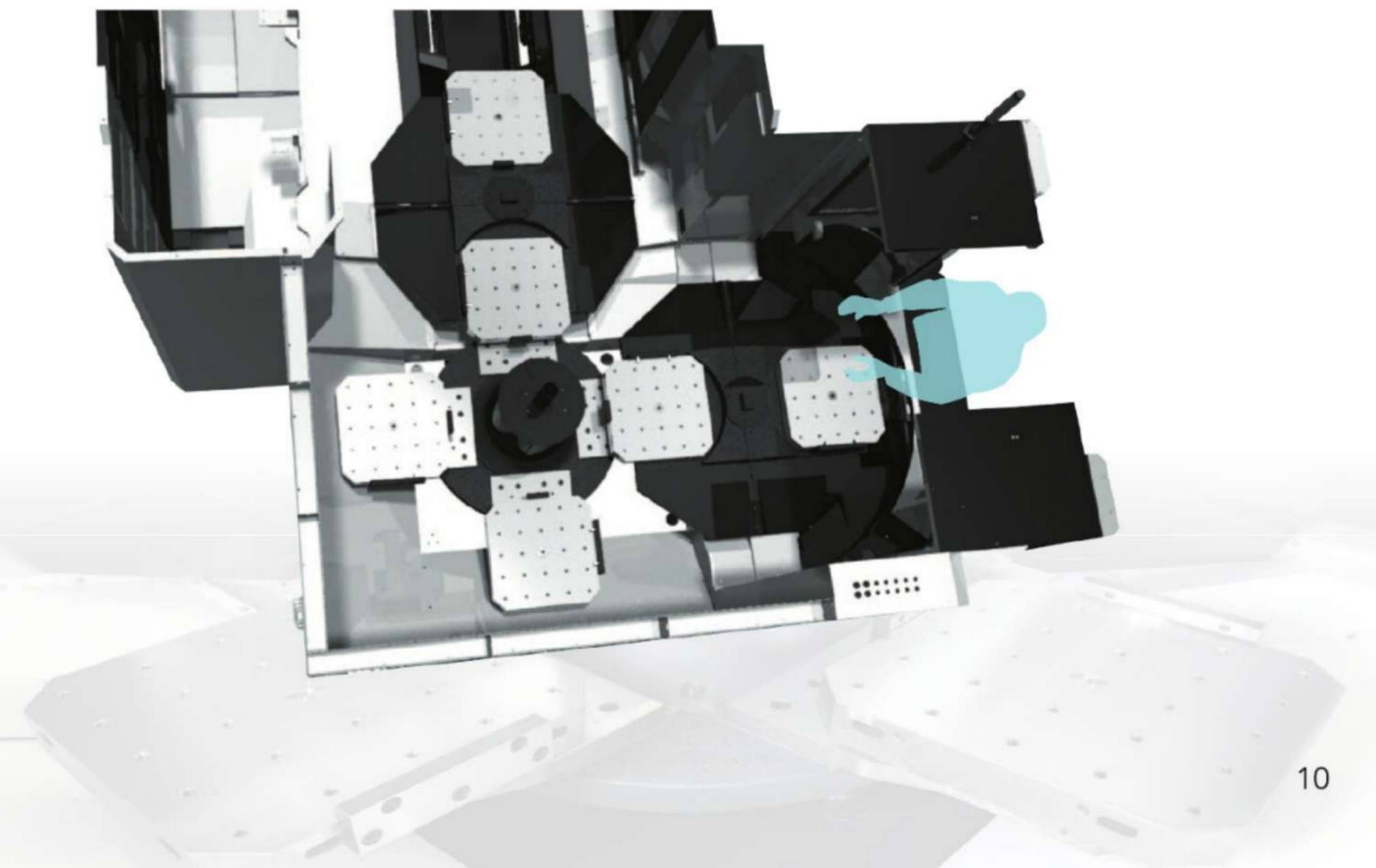

Efficient Chips Evacuation

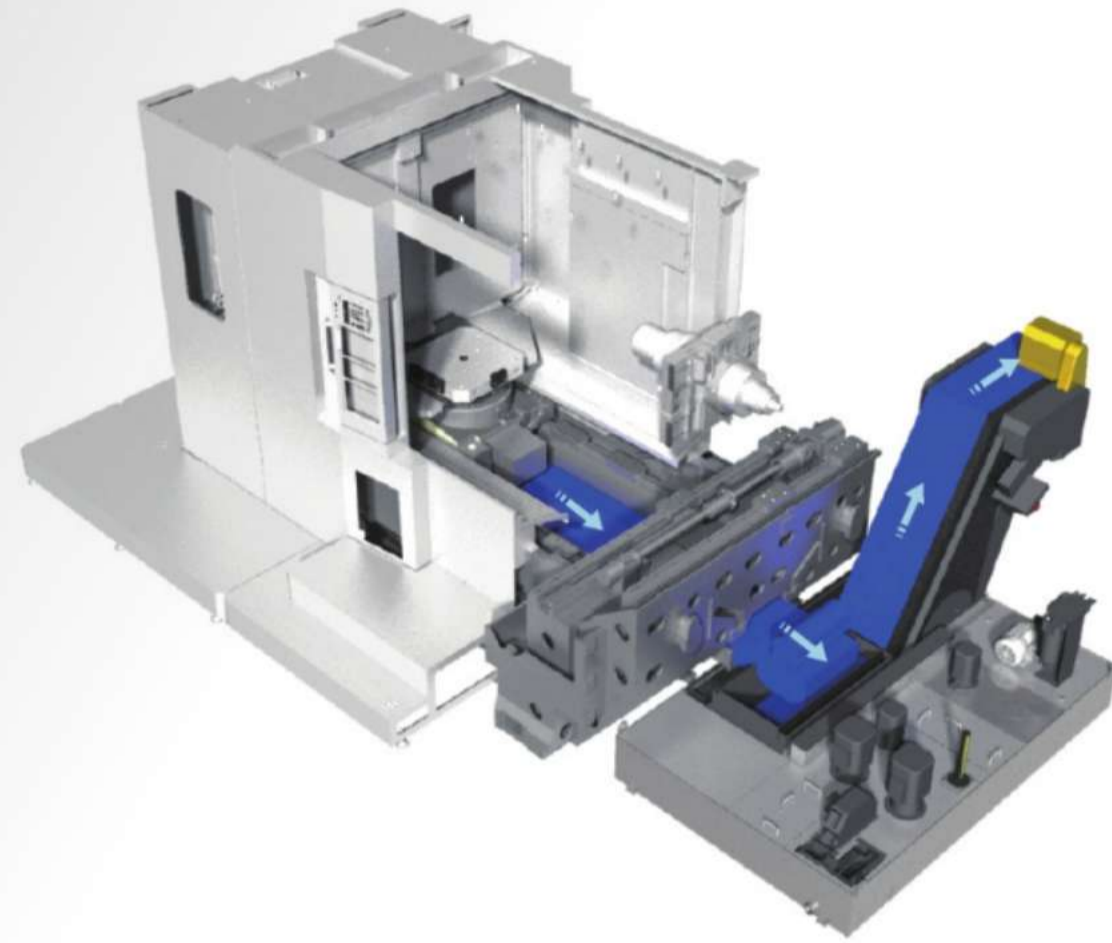

Coolant Shower ST

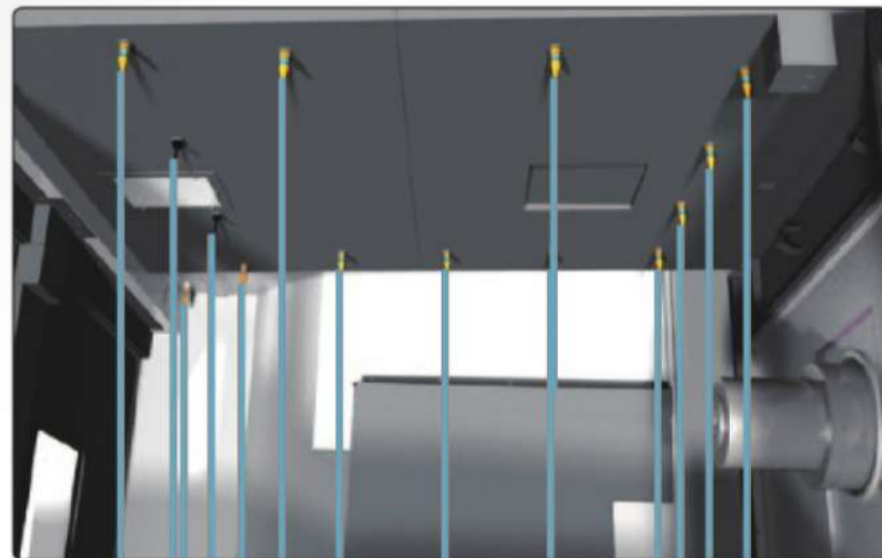

Flush Coolant System ST

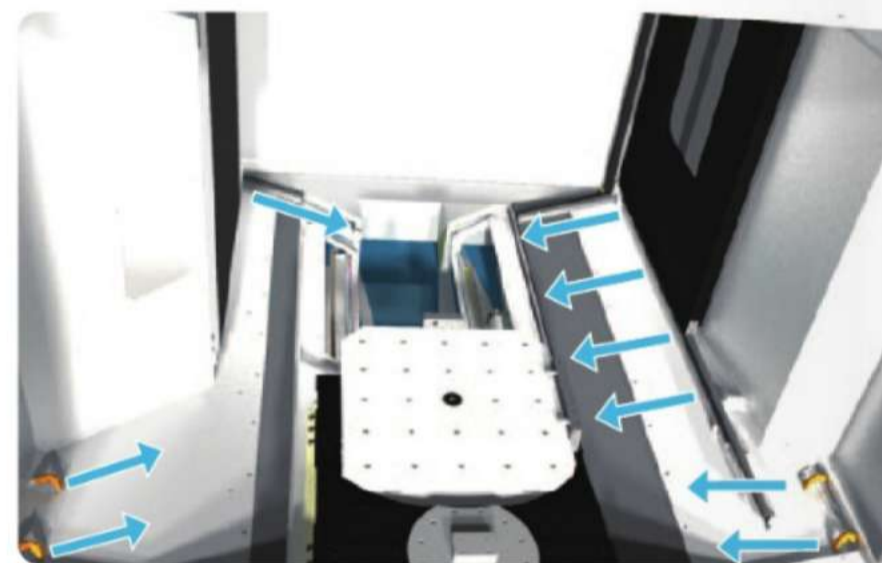

(Photo shows HS-630i with optional scraper roller type chip conveyor.)

Large Capacity Coolant Tank ST

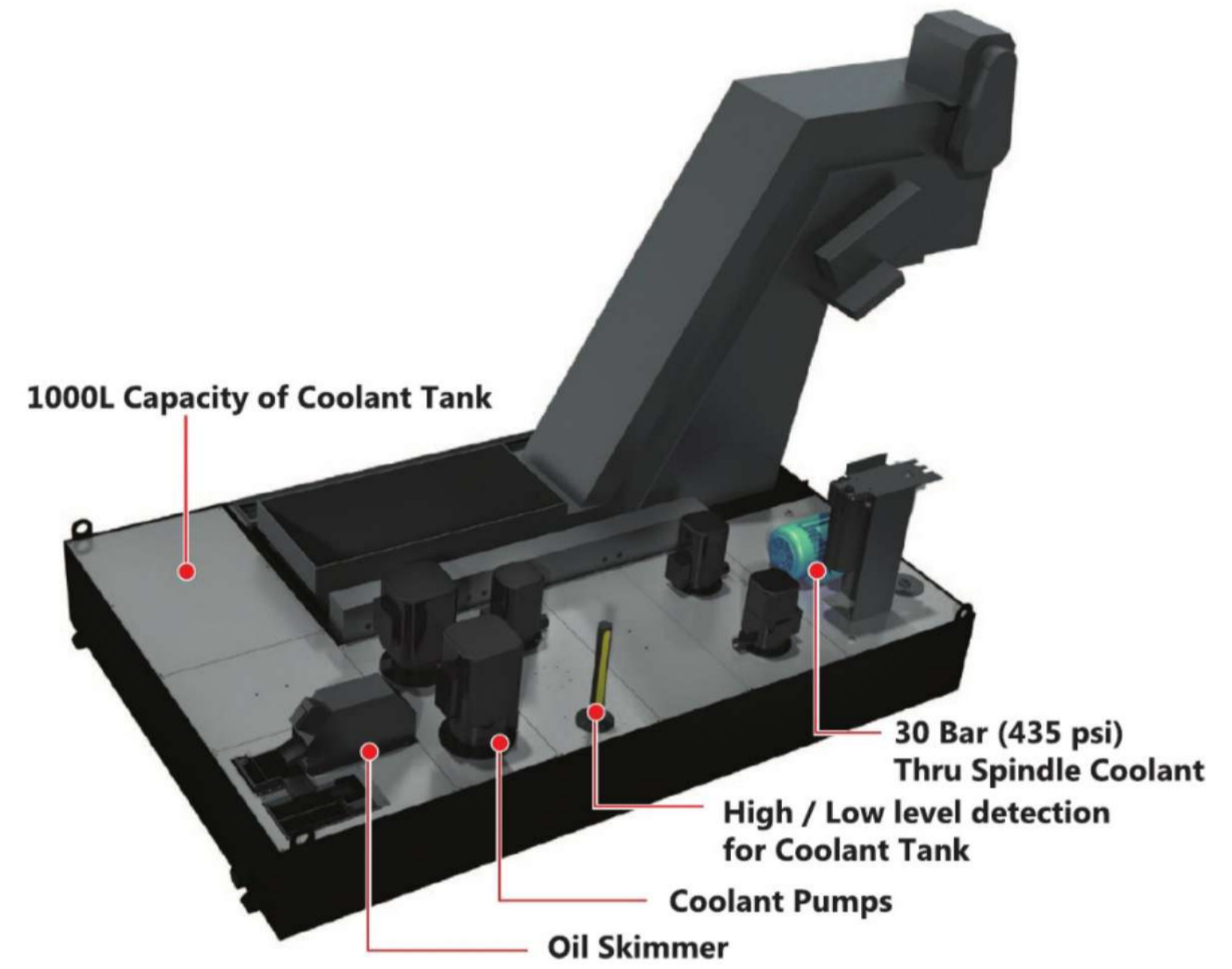

Chip Conveyor OP

Chip Type	Curly Iron Chip	Metallic Chip	Non-Curly Chip	Foundry Chip	Curly Aluminum Chip	Aluminum Chip	Brass Chip	Non-Metallic Chip
Steel Belt Type	●	●			●			●
Scraper Roller Type			●	●		●	●	
Magnetic Scraper Type			●	●				
Dual Belt Roller Type	●	●	●	●	●	●	●	●



Steel Belt Type

Scraper Roller Type

Magnetic Scraper Type

Dual Belt Roller Type

Operation & Maintenance

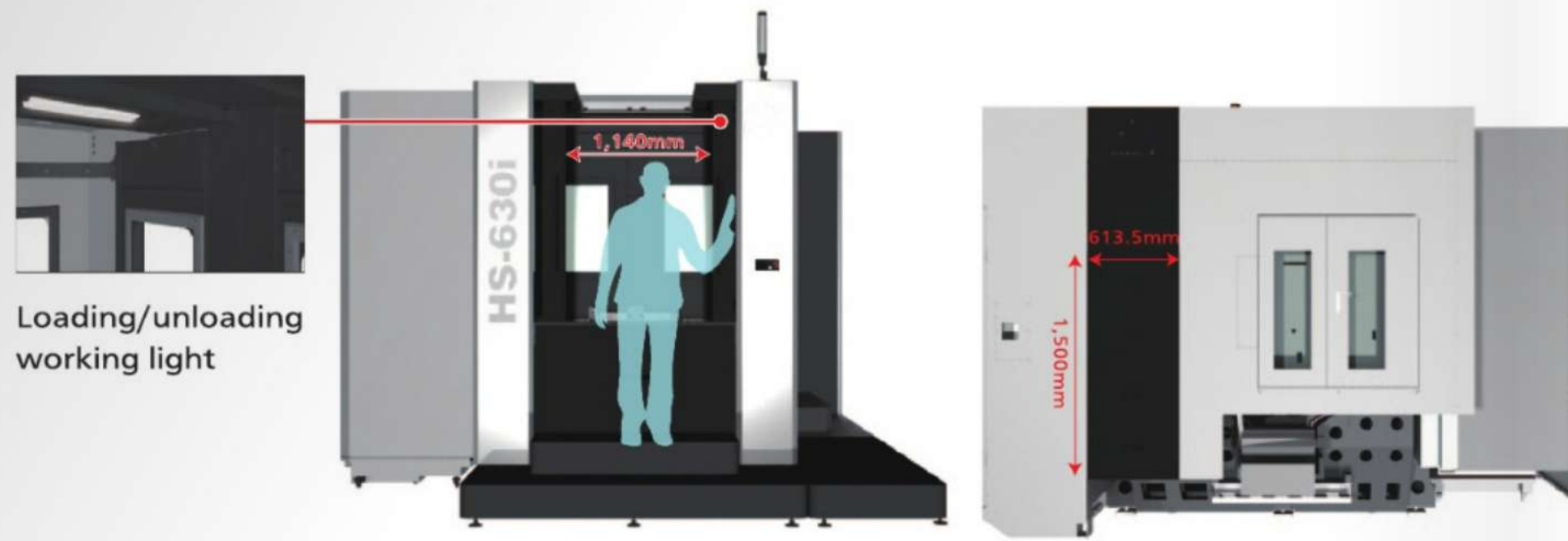

Loading/unloading working light



iPad monitor



Machining zone working light



24/7 Weekly Timer



Heat Exchanger

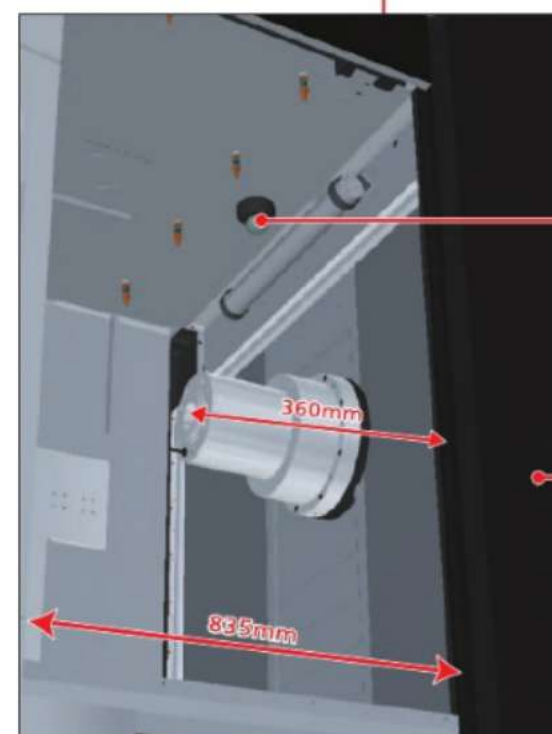
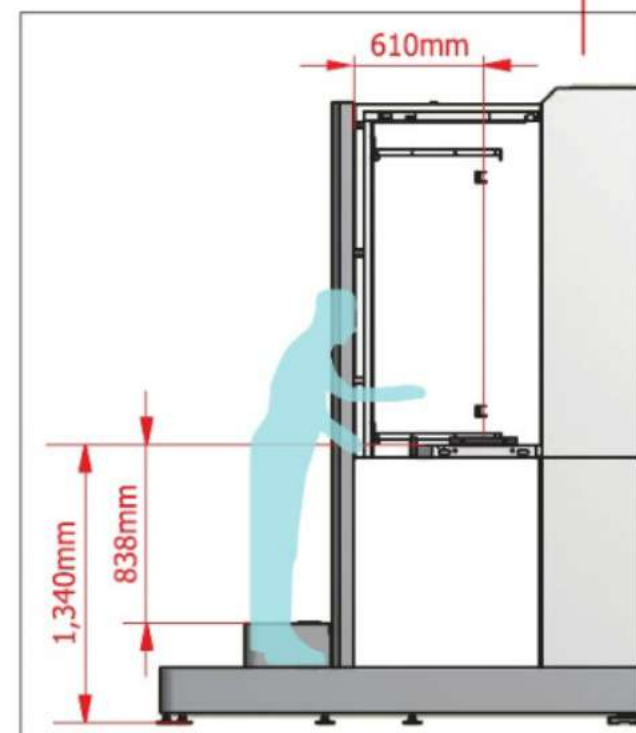

Monitoring Camera



Manual tool clamp/unclamp

Optional Accessories

Optical Scale (X.Y.Z.B)



70 Bar (1,000 psi) Coolant Thru Spindle



Work Piece Measurement

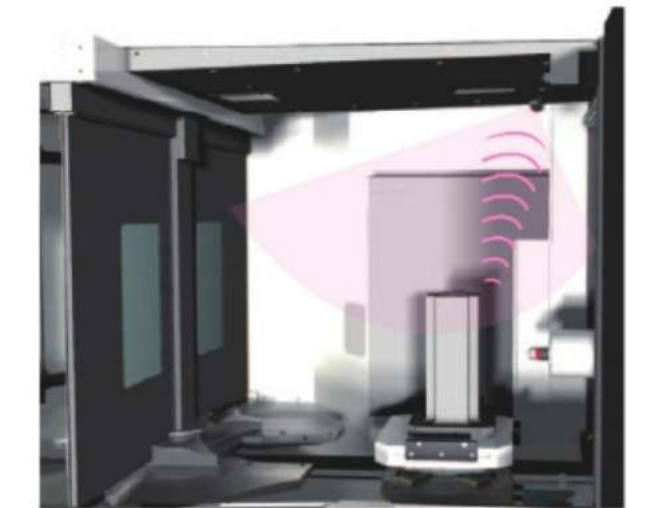

Tool Life Management

Touch Probe

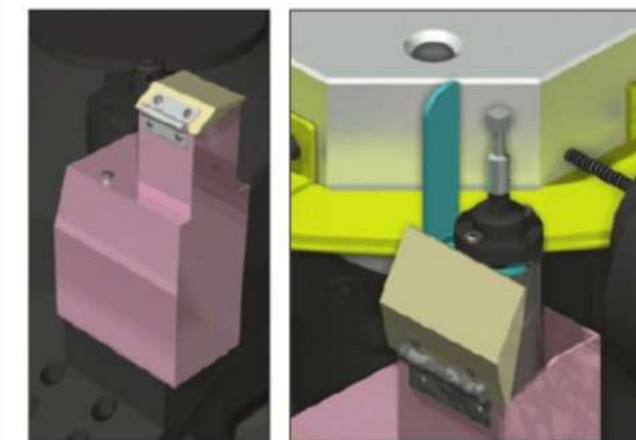

Laser

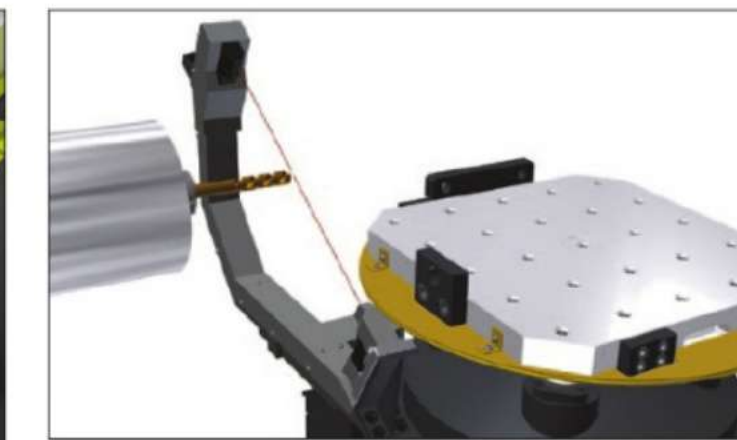

Tool Breakage Detection System (magazine)

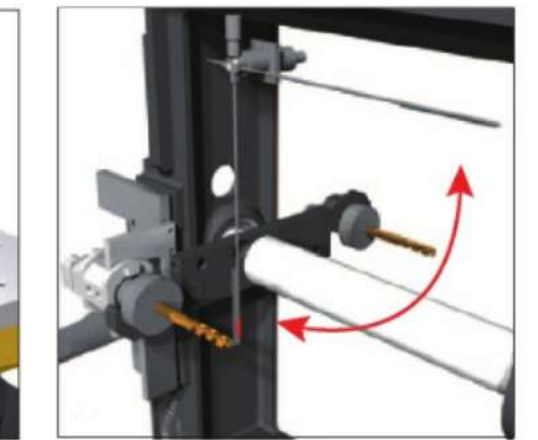

Window Spinning Wiper



Hydraulic Overhead Arms for Fixture

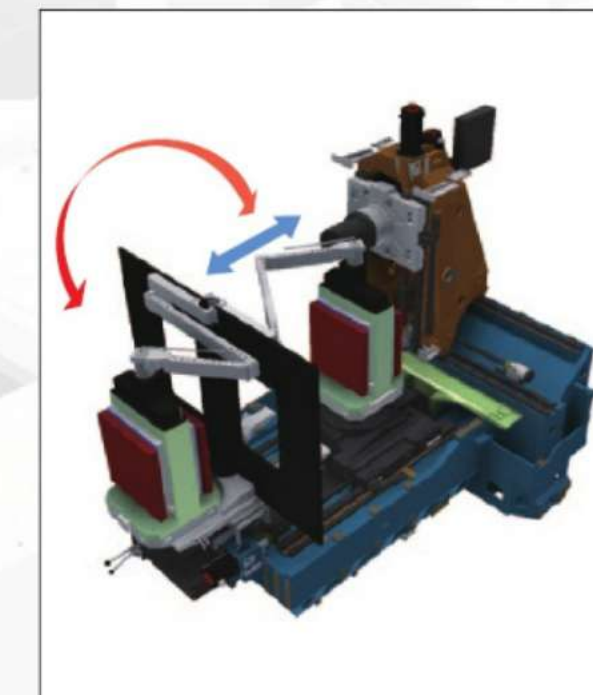

Coolant Mist Collector

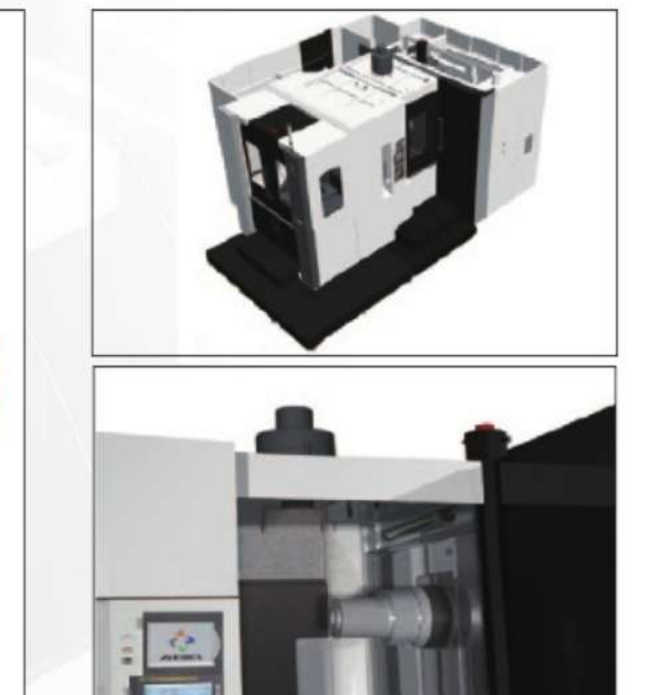

SMARTux-FANUC MPro III

Special Value Package



- 10.4" Color LCD
- AICC II Nano Control with 200 Blocks Look Ahead
- JERK Control
- HRV- III+ High Performance Servo Drives
- 300 Pairs Workpiece Coordinate Offsets
- Helical Interpolation
- Circular Interpolation
- Rigid Tapping
- Canned Cycle
- Ethernet and CF/USB Device
- Tool Life Management
- Tool Offset Memory C
- Manual Guide i
- 1,280 meter Part Program Memory
- Custom Macro B
- 1,000 Registerable Programs
- Programmable Spindle Tool Load Monitoring
- Programmable Data Input G10

Optional

- Full 4 axes control
- Stored stroke check 2
- Manual handle interruption
- Single direction positioning
- Cylindrical interpolation
- F1-digit feed
- Addition of optional block skip
- Polar coordinate command
- Optional chamfering/corner R
- Program mirror image
- Scaling
- Coordinate system rotation
- Tool offset memory B
- Playback function
- 6 Pallet management table
- Data server with high speed (Ethernet and 1GB memory)
- High speed skip
- Tool offset capacity 400 pcs
- AI contour control II, High-Speed processing 600 buffer blocks/ 1000 buffer blocks
- Nano smoothing
- Tool offset G45 to G48
- Program restart
- Interruption type custom macro
- Custom macro-common variables # 600 ~ # 999
- Dynamic fixture offsets
- Built-in 3D interference check, 300 pairs tool geometry size data

Pallet

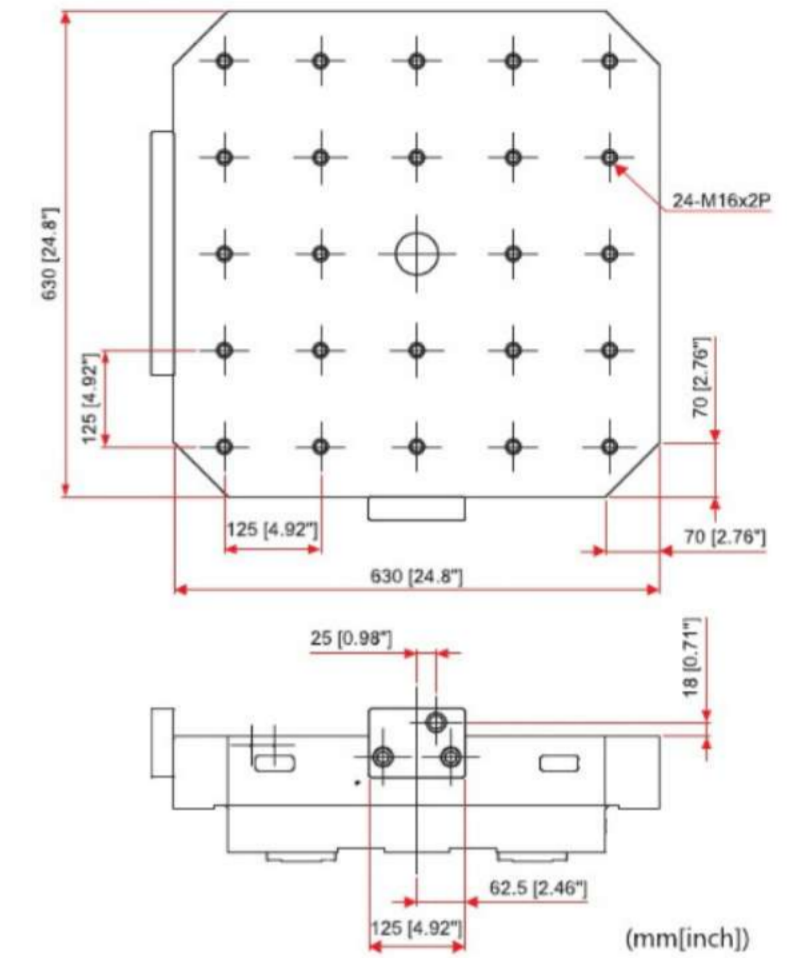
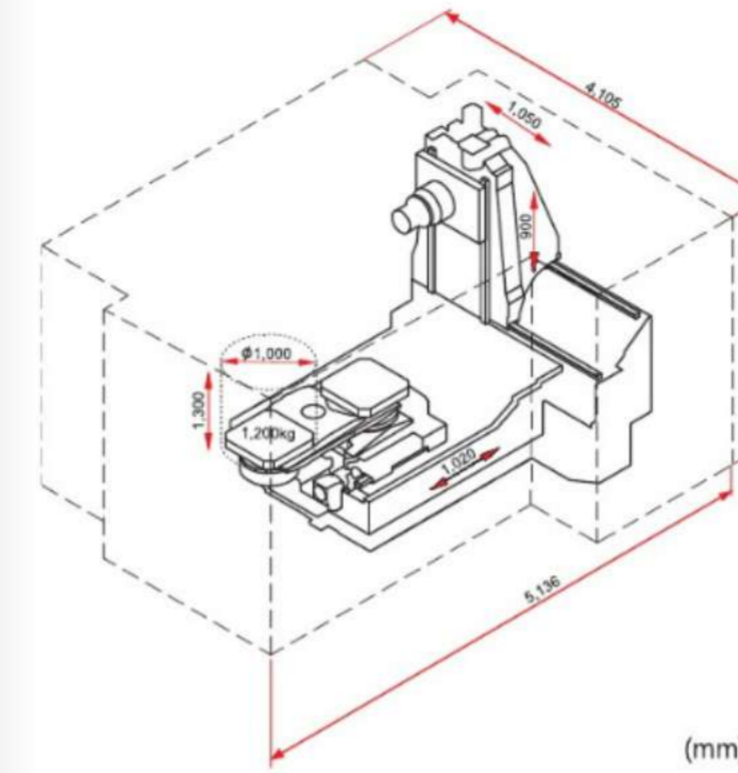

Working Zone

Item	Description	mm [inch]	
		10,000 rpm Spindle	8,000 rpm Spindle (Opt.)
y	Y-axes Travel	900 [35.4"]	880 [34.6"]
x	X-axes Travel	1050 [41.3"]	
z	Z-axes Travel	1020 [40.2"]	
Sz	Spindle Nose to Pallet Center	50 [2.0"]	
Sy	Spindle Center to Pallet Surface	80 [3.1"]	100 [3.9"]
Iy	Y-axes Interference	210 [8.3"]	260 [10.2"]
Iz	Z-axes Interference	315 [12.4"]	
Wh	Max. Workpiece Height	1300 [51.2"]	
Wd	Max. Workpiece Diameter	1000 [39.4"]	

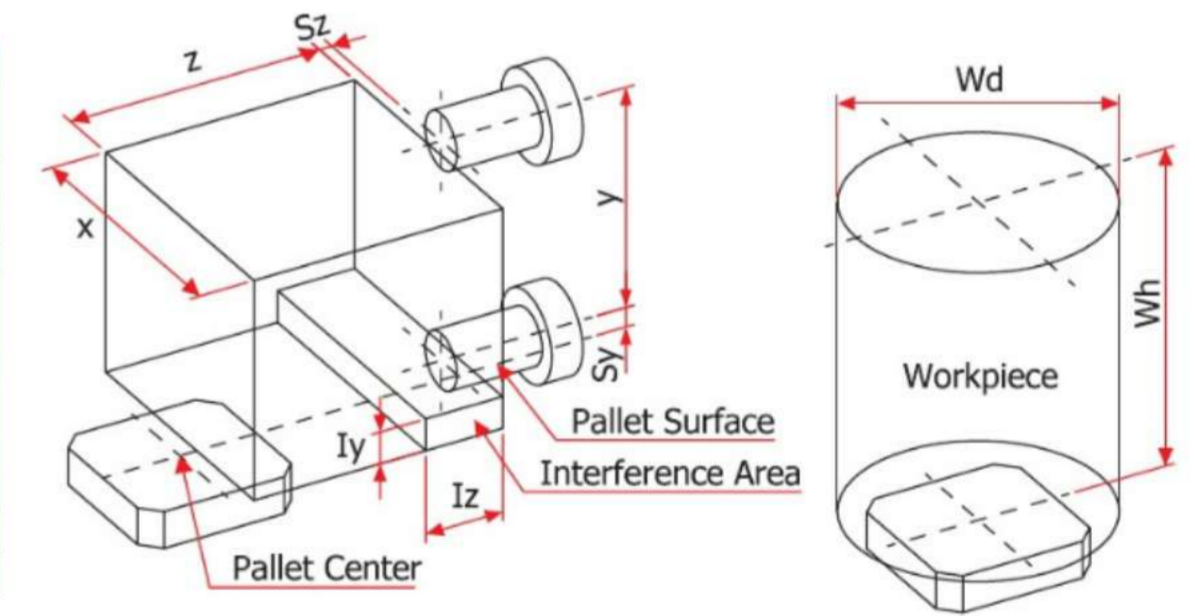

Tool

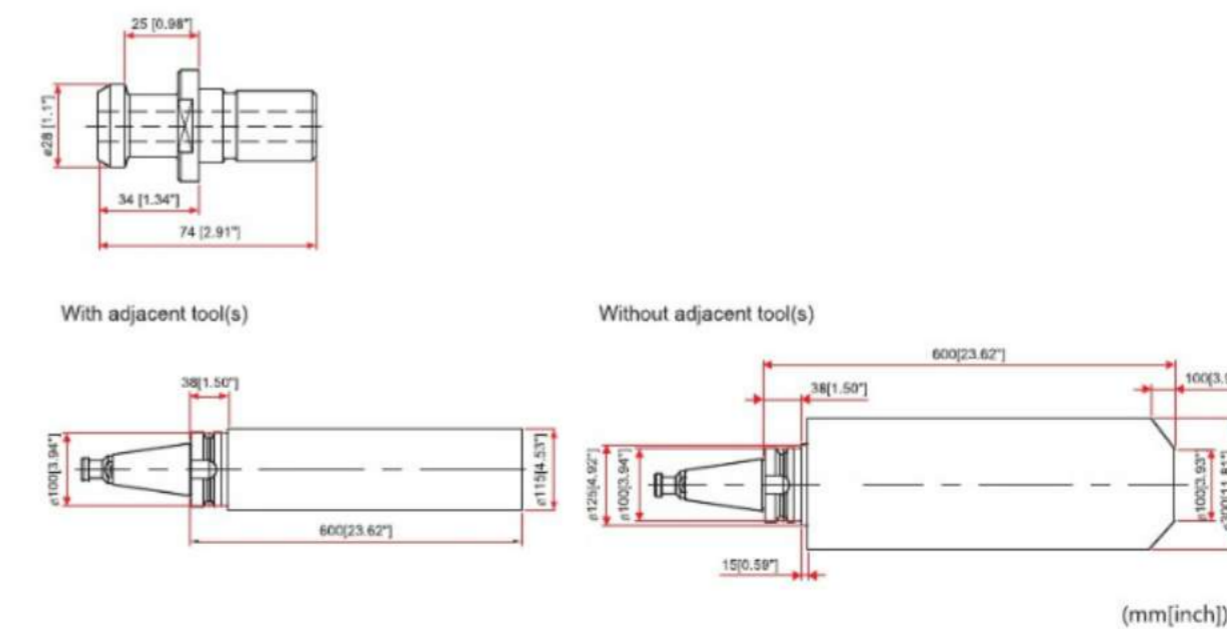

Tool Restriction	BBT	CAT	DIN
Max. Tool Diameter	φ115mm[4.53"]		
Max. Tool Length	600mm[23.62"]		
Max. Tool Weight	25kg[55lb]		
Max. Tool Diameter (no adjacent tools)	φ300mm[11.81"]		
Pull Studs	JIS50P M24x3P	DIN 69872(UNC) 1"-8 UNC	DIN 69872 M24x3P

Standard Features

Number of controllable axes	4 axes (X/Y/Z/B)
Number of simultaneously controllable axes	4 axes (X/Y/Z/B)
Least input increment	0.001 mm
Least setting increment	0.001 mm
Bell shaped acceleration/deceleration before look-ahead interpolation	
HRV III high performance axis drives	
Inch/metric conversion	
AI contour control II	200 buffer blocks
Position Switch	
FEED FUNCTION	
Cutting feed override	0 ~ 200% (by 10%)
Dwell	G04
Zero point return	G27 to G30
Handle feed	0.001/0.01/0.1mm
Manual Jog feed	0 to 2000mm/min. (20 steps)
Dry run	
Rapid traverse rate override	0, 8, 15, 25, 50, 100 (%)
TOOL FUNCTION	
Tool function	4-digit T code
Cutter compensation C	G40 to G42
Too length compensation	G43, G44, G49
Tool offset capacity	200 pcs
Tool offset memory C	
Tool life management	
Tool radius / tool nose radius compensation	
EDITING FUNCTION	
Tape code	EIA RS244/ISO 840 Automatic recognition
Input/output interface	RS232C
Part program storage length	512 Kbyte
Number of registered programs	1,000 pcs
Search function	Program number search Sequence number search Address search
Extended part program editing	
Background editing	

SPINDLE FUNCTION

Spindle speed function	5-digit S code
Spindle speed override	50~150% (by 10%)

PROGRAM INPUT

Absolute/incremental programming	G90 / G91
Canned cycles	G73, G74, G76, G80 to G89
Inch/metric conversion	G20 / G21
Decimal point programming	Input by using decimal point
Circular interpolation by R programming	
Subprogram call	10 folds levels nested
Local/Machine coordinate system	G52 / G53
Workpiece coordinate system	G54 - G59
Addition of work coordinate system	300 sets
Max. programmable dimension	±9-digit
M function	3-digit M code
Custom macro B	

OTHERS

MDI/LCD Unit	10.4" Color LCD, Keyboard, and Soft Keys
Programmable Data Input	G10
Rigid tapping	Synchronized tapping
Stored stroke check 1	
Help function	Explanation of alarm messages
Run hour and parts count display	
Operating monitor display	
Stored pitch error compensation	
English language display	
Multi-language display	
Thread cutting	
Synchronous cutting	
Helical interpolation	
Ethernet function	

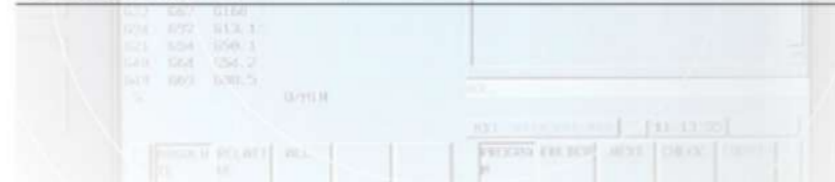

2 APC with 60 Tool ATC

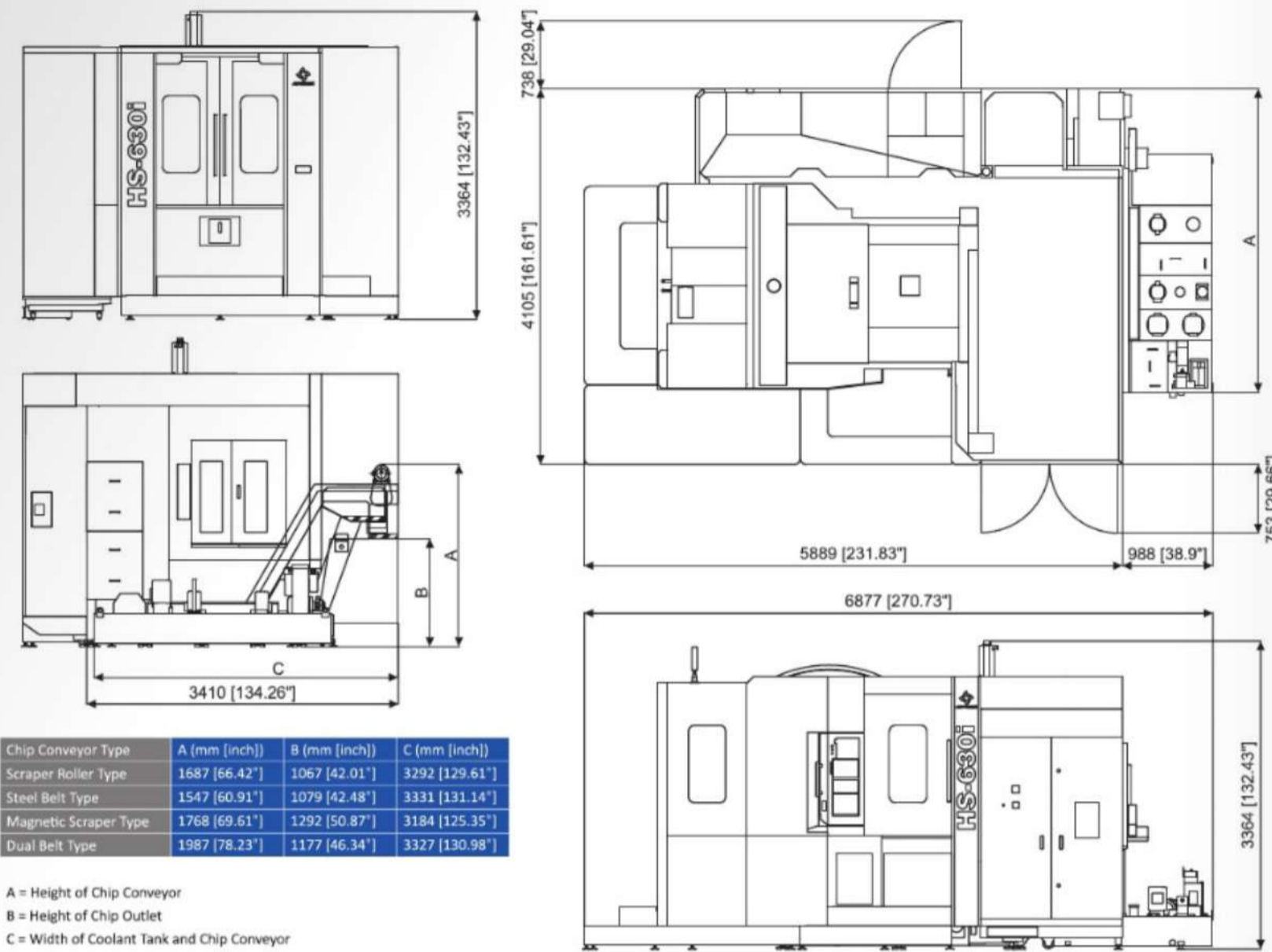

6 APC with 60 Tool ATC

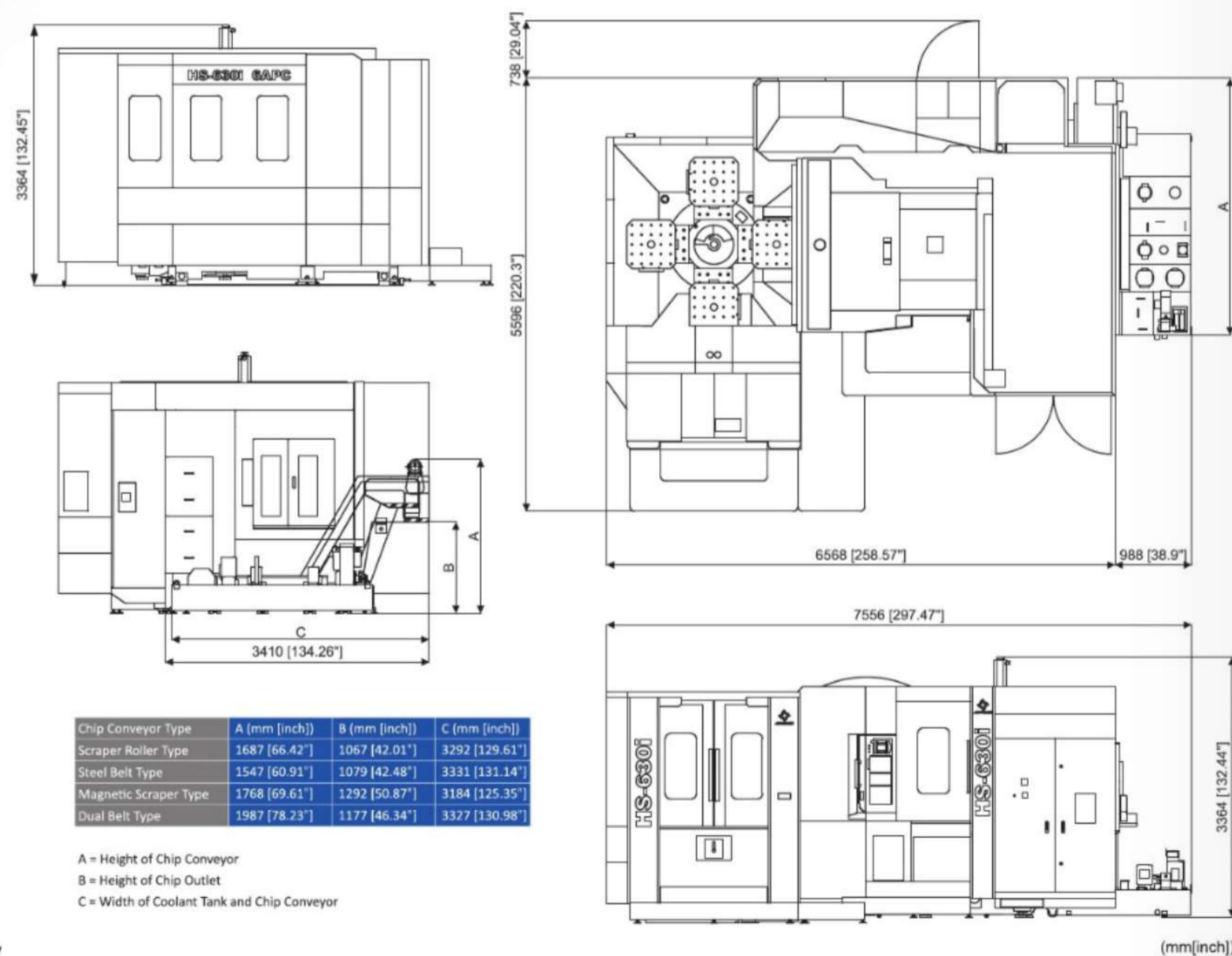

HS-630i with SMARTux-FANUC MPro III SPECIFICATIONS

	DESCRIPTIONS	IMPERIAL	METRIC
TRAVEL	X-axis, Y-axis, Z-axis	41.3", 35.4", 40.2" (10,000 rpm Spindle) 41.3", 34.6", 40.2" (8,000 rpm Spindle)	1050 mm, 900 mm, 1020 mm (10,000 min ⁻¹ Spindle) 1050 mm, 880 mm, 1020 mm (8,000 min ⁻¹ Spindle)
	Spindle center to pallet surface	3.1" - 34.6" (10,000 rpm Spindle) 3.9" - 34.6" (8,000 rpm Spindle)	80 - 980 mm (10,000 min ⁻¹ Spindle) 100 - 980 mm (8,000 min ⁻¹ Spindle)
	Spindle nose to pallet center Pallet top height (from the floor)	2.0" - 42.1" 52.4"	50 - 1,070 mm 1,330 mm
TABLE	Table size (2 pallets)	24.8" x 24.8"	630 mm x 630 mm
	Workpiece max. size	Ø39.4" x 51.2"	Ø1,000 mm x 1,300 mm
	Max. payload	2,640 lb	1,200 kg
	Configuration	M16x30L P=4.9"	M16x30L P=125 mm
	Min. indexing degree	1° (0.001° Optional)	1° (0.001° Optional)
	Indexing speed	2.2 sec./90° (2.0 sec./90° Optional)	2.2 sec./90° (2.0 sec./90° Optional)
	Pallet clamping system Pallet clamping force B-axis clamping torque	Mechanical Lock 3,590 lb x 4 cones 36,140 lb-ft (3,023 lb-ft Optional)	Mechanical Lock 16 kN x 4 cones 49,000 Nm (5,500 Nm Optional)
SPINDLE	Spindle speed	20-10,000 rpm (8,000 rpm Optional)	20-10,000 min ⁻¹ (8,000 min ⁻¹ Optional)
	Spindle rated torque	442 lb-ft (15%ED) 309 lb-ft (15 min.) 885 lb-ft (10%ED) (8,000 rpm Optional) 481 lb-ft (30 min.) (8,000 rpm Optional)	600 Nm (15%ED) 420 Nm (15 min.) 1202 Nm (10%ED) (8,000 min ⁻¹ Optional) 653 Nm (30 min.) (8,000 min ⁻¹ Optional)
	Spindle acceleration / deceleration	5.5 sec. (0-10K rpm) / 5.5 sec. (10K-0 rpm)	5.5 sec. (0-10K min ⁻¹) / 5.5 sec. (10K-0 min ⁻¹)
	Spindle taper	ISO 7/24 Taper NT No. 50	ISO 7/24 Taper NT No. 50
	Through spindle coolant	435 psi	3.0 MPa
FEED	Rapid feed (X/Y/Z)	1,969 ipm	50,000 mm/min
	Cutting feed (X/Y/Z)	0.04-1,969 ipm	1-50,000 mm/min
	Table rotating speed	Parkson: 16.6 rpm Tsudakoma: 22.2 rpm	Parkson: 16.6 min ⁻¹ Tsudakoma: 22.2 min ⁻¹
	Guide ways (X/Y/Z) Acceleration (X/Y/Z) Ball screws size	Roller ways [THK] 0.7 G/1.0 G/0.9 G Ø1.97"	Roller ways [THK] 0.7 G/1.0 G/0.9 G Ø50 mm
ATC	Type of tool shank	BBT 50 / CAT 50 (Optional)	BBT 50 / CAT 50 (Optional)
	Type of pull-stud	JIS / CAT 50 (Optional)	JIS / CAT 50 (Optional)
	Number of tools	60	60
	Max. tool diameter (Adjacent pots full / empty)	Ø4.5" / Ø11.8"	Ø115 mm / Ø300 mm
	Max. tool length	23.6"	600 mm
	Max. tool weight	55 lb	25 kg
	Tool selection system Tool to tool Chip to chip	Random 2.5 sec. (3.5 : Heavy tool programmable) 5.8 sec. (6.8 : Heavy tool programmable)	Random 2.5 sec. (3.5 : Heavy tool programmable) 5.8 sec. (6.8 : Heavy tool programmable)
APC	Number of pallets	2, Optional 6	2, Optional 6
	Pallet change system	Rotation	Rotation
	APC exchange time	15 sec.	15 sec.
MOTOR	Spindle motor	60 / 50 hp	45 / 37 kW
	Feed axes motors (X/Y/Z/B)	7.4 / 6.7 / 7.4 / 5.4 hp	5.5 / 5.0 / 5.5 / 4.0 kW
	Lubrication pump motor	0.024 hp	18 W
	Spindle coolant pump	2.2 hp	1.62 kW
	Chips flush (base) coolant pump	2.7 hp	2.03 kW
	Through spindle coolant pump	3.0 hp	2.24 kW
	Overhead shower flush coolant pump	3.2 hp	2.35 kW
	Hydraulic pump	3.0 hp	2.23 kW
Spindle oil chiller	7.2 hp	5.40 kW	
SUPPLY	Electric voltage	200 - 230 volt	200 - 230 volt
	Electric power supply	70 kVA	70 kVA
	Air pressure	87.0 psi	0.6 MPa
	Air volume	174 gal/min	660 liter/min
TANK	Hydraulic unit tank	15.9 gallon	60 liter
	Coolant Tank	264.2 gallon	1,000 liter
	Lubrication unit tank	0.79 gallon	3.0 liter
SIZE	Machine dimension (L x W x H)	270.7" x 161.6" x 132.4"	6,877 x 4,105 x 3,364
	Required floor space (L x W x H)	302.2" x 220.3" x 132.4"	7,677 x 5,595 x 3,364
	Machine weight	40,124 lb	18,200 kg

SMARTux HS-630i

**ULTRA *HIGH-SPEED* PRECISION
HORIZONTAL MACHINING CENTER**



**CINCINNATI
MACHINES**

World Headquarters
2060 Reading Rd. Suite 130 Cincinnati, Ohio 45202
<https://cinmac.com> (513) 681-1953 sales@cinmac.com parts@cinmac.com