

CINCINNATI MACHINES

Monaset XL

Tool & Cutter Grinder

Cincinnati Machines' Monaset XL Tool and Cutter Grinder is the industry standard for sharpening, reconditioning, and even making cutters from solid stock. The infinitely variable spiral lead mechanism coupled with the swivelling turntable and offset slide make the Monaset Cutter and Tool Grinder the clear choice when it comes to grinding or sharpening complex shapes and forms, like the spiral flute of a typical milling cutter.



INFINITELY VARIABLE SPIRAL LEAD MECHANISM

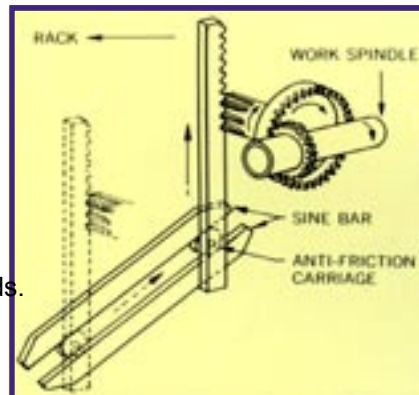

Spiral mechanism generates infinitely variable leads



Monaset XL retains all of these features while adding the accuracy and smooth feel of ballscrews

Monaset boasts seven axis movements on dual machine slide stacks plus its unique spiral mechanism that generates infinitely variable leads. The dual swivelling and dual linear slide workhead has proven to be a real asset when grinding radii. The offset slide for the grinding wheelhead permits the spindle centerline to be offset from the workhead centerline - a necessity when grinding concave or convex radii with centerline outside of the workpiece.

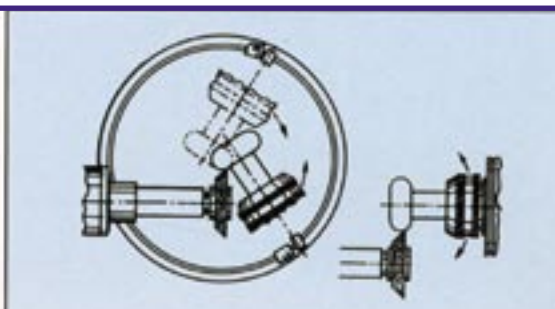
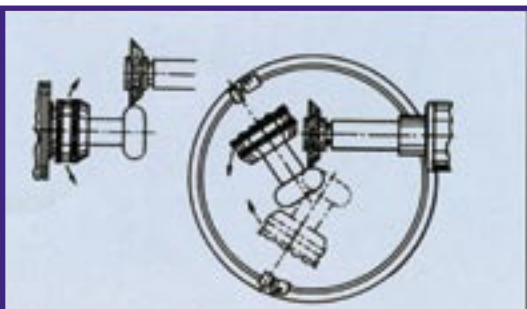

Monaset's combination swivelling turntable and moveable offset slide provide your shop with versatile capabilities to quickly set up and accurately generate concave and convex radii of varying sizes.

STANDARD EQUIPMENT

- *Toothrest assy. with extension bar
- *Grinding wheel guards
- *Front stock support
- *Diamond holder
- *Toolbox
- * (4) standard wheel collets
- * (1) extended wheel collet
- *Lower stock support
- *Spanner wrenches
- *Spindle center gauge
- *Adjustable tailstock support
- *Leveling pads
- *Misc. wrenches/tools
- *Index plates
- *Tilting, swivelling workhead
- *Swivelling turntable work slide
- *Offset slide
- *Operator/parts/service manual

OPTIONAL ACCESSORIES

- *Large radius grinding Attachment
- *1/2" hole grinding wheel mount
- *4" universal 6 jaw chuck
- *Index pawl for index plates
- *Index plates
- *Set of straight collets/adaptors
- *Set of 3 taper collets, 5,7,9 B&S



Monaset XL



CHOOSE YOUR RADIUS TYPE

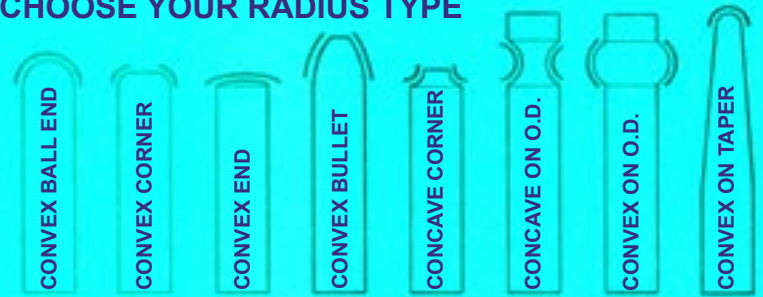

SPECIFICATIONS

WORKHEAD

Swing over main slide, (max diameter).....	12"
Collet work diameter.....	12 - 1.25"
Minimum lead generated by spiral lead mechanism.....	1.81"
Maximum length between spindle nose and tail center.....	6"
Main slide travel.....	5.75"
Offset slide travel, total.....	5.25"
-front of center.....	3"
-rear of center.....	2.25"
Horizontal swivel.....	235°
Vertical swivel.....	+/-40°
Workhead power.....	1/4 hp
Workhead speed.....	436rpm

WHEELHEAD

Longitudinal slide travel.....	6"
Vertical slide travel.....	9.5"
-above center.....	4.5"
-below center.....	5"
Cross slide travel, total.....	7.5"
-front of center.....	3"
-rear of center.....	4.5"
Wheelhead power.....	1/2 hp
Wheelhead speed.....	4000, 5729, 8000 rpm

SPACE/WEIGHT

Overall floor space requirements.....	60" x 67"
Machine weight.....	1525 lbs.

MACHINE DIMENSIONS

